

# *Freshline™ Batch Freezer*

*For fast, economic, discontinuous freezing of cook-chill and cook-freeze products*

- *High performance*
- *Versatile*
- *Easy to use*
- *Uses liquid nitrogen at  $-196^{\circ}$*





**Air Products'  
Freshline™ Batch**

The Air Products Freshline™ Batch unit uses the unique qualities of liquid nitrogen refrigeration for fast economic chilling or freezing of foods. The Freshline™ Batch has been specifically designed to meet the stringent needs of cook-chill and cook-freeze in the catering industry. It is also ideal for food processors with batch or low volume freezing/chilling requirements.

### How does it work?

The Freshline™ Batch liquid nitrogen refrigeration system consists of an insulated food grade stainless steel cabinet with three custom designed fans and liquid nitrogen injection system. Liquid nitrogen at -196°C is injected into the fan generated gas stream. The super cooled gas stream passes evenly over the tray or trolley mounted containers quickly refrigerating the products. Typically the Freshline™ Batch takes 20 minutes to refrigerate 100 kg of product. Both in-out and straight through versions are available for both multirecipe and standard.

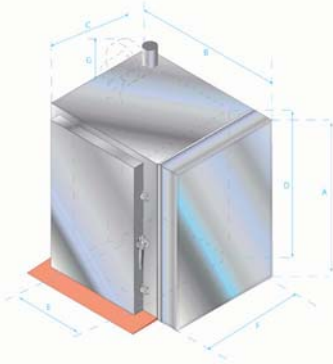

### Technical data

Model	CB1200	CB2400
External height A	2125mm	2265mm
External width B	1572mm	2092mm
External depth C	1650mm	1650mm
Internal height D	2000mm	2140mm
Door width E	730mm	1250mm
Internal depth F	1400mm	1550mm
External height G	2720mm	2685mm
Volume	1.2m <sup>3</sup>	2.4m <sup>3</sup>
Weight	1200kg	1800kg

Electrical supply: 3 Phase 400V 50Hz 12A max.

Liquid nitrogen supply: 15mm, stainless steel or Cu Pipe.

Maximum refrigeration capacity: 60-90 kW.

Normal refrigeration capacity: 25-50 kW.

Air pressure: 5-7 barg.

Exhaust details: stainless steel ductwork 200 mm diameter; connected to exterior of the building.

### Freshline™ Batch Multirecipe:

- Permanently stores eight freezing/chilling recipes
- Recalls recipes at touch of a button
- Contains the normal temperature and time variables
- Freshline™ Batch temperature can be varied throughout the timed recipe
- Prevents edge freezing whilst maintaining high cooling rates
- Alpha-numerical display shows process time and batch temperature updates
- Onsite operator training provided
- Designed to accept industry standard trolleys eg. GASTRONORM

### Freshline™ Batch Standard

If the requirement is for continuous processing of a single product, the Freshline™ Batch Standard has been manufactured with simplicity in mind.

The Freshline™ Batch Standard features the same fans and liquid nitrogen injection system as the Freshline™ Batch Multirecipe except that the temperature and process time are manually set. To maximise efficiency a separate time controlling the liquid nitrogen injection time has been incorporated, allowing residual cold to be transferred to the product.

**tell me more**  
[www.airproducts.com/food](http://www.airproducts.com/food)  
 e-mail: [freshli@airproducts.com](mailto:freshli@airproducts.com)

#### Freshline UK

Air Products PLC  
 2 Millennium Gate, Westmere Drive  
 Crewe, Cheshire CW1 6AP  
 Tel 0800 389 0202 Fax 01932 258502